

THE NEW DIMENSION TO MOBILE ICE MAINTENANCE

Catalogue
Pinguino



Catalogue
Pinguino

INDEX

Company	5
Pinguino	11
Strengths	39
Products	43

COMPANY

Young, dynamic, and innovative:
At WM technics, progress and
customer satisfaction come first.

Established in 1986, WM technics crafts premium **ice resurfacing machines** suitable for every surface and requirement. Our state-of-the-art models stand out with their advanced technology, user-friendly operation, certified safety, and contemporary design.



Ice resurfacing machine
WM 2300.
Year of construction 1986

Here's what we have to offer

Whether catering to professional ice needs within an arena or on a transportable rink, the distinction is minimal: WM technics consistently offers the optimal solution for any requirement. Owing to our relentless pursuit of product excellence, we pioneer cutting-edge standards and stand as a prominent leader in the worldwide market. Powered by our robust digital infrastructure; design, parts production, and the assembly of ice resurfacing machines are conducted at our South Tyrol-based facility (Italy). In this

manner, WM technics guarantees unparalleled quality, attending to every intricate detail. Custom setups built on customer specifications, reduced maintenance commitment, and steadfast assistance affirm WM technics as a powerful ally.



Marcel,
Assembly Team

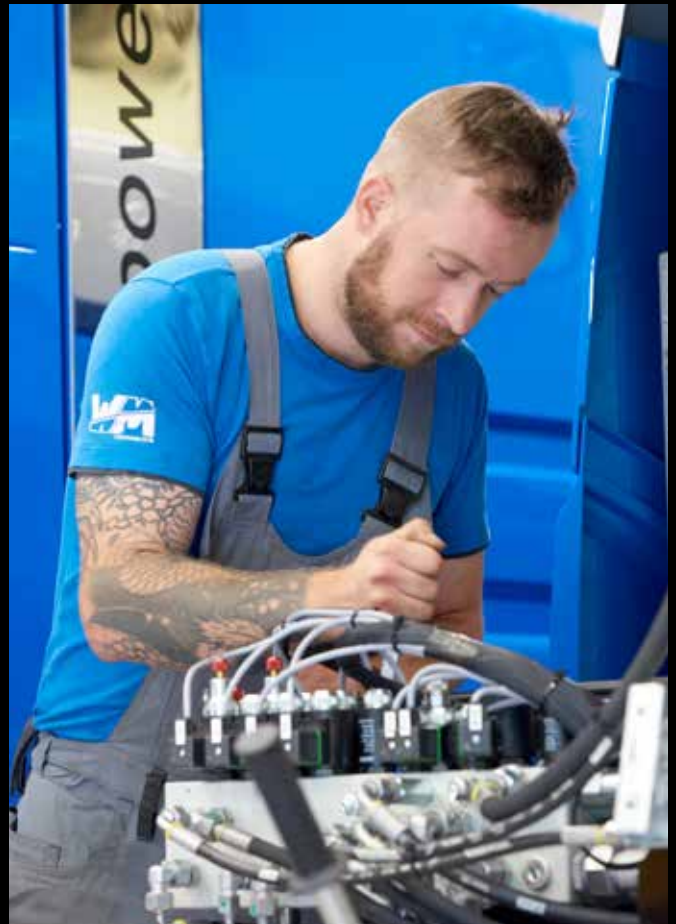



Always Ahead of the Curve

With precision, we delve into research, trials, and systems. Our team's years of prowess in development, manufacturing, and setup culminate into a harmonious synergy.



Safety at its Finest

Our cardinal rule: Prioritizing safety and well-being. WM technics' ice machines are designed with intuitiveness and uncompromised safety, meeting European machinery guidelines.



Design with a Spark

WM technics brings to life trailblazing ice machines, always keeping the client and entire production lifecycle at heart.



Precision Production

WM technics manufactures all its turning and milling components with utmost precision in its production department, only sourcing standard parts from reputable manufacturers. Each component is then customized in detail based on its function and crafted with the greatest care.



Streamlined Assembly

WM technics champions the rapid production of ice machines, backed by rigorously organized processes. Every move is intricately mapped and transparent. Our commitment to precision minimizes the need for maintenance.



360-Degree Quality

WM technics designs and produces innovative ice resurfacing machines that meet all efficiency, reliability, longevity, and ease-of-use requirements. Series construction and in-house production also allow for the detailed tracking of all fabrication stages and utilized components.



Sustainability with Vision

WM technics machines are designed to stand the test of time. We advocate for enduring products while keeping an eye on operational expenses. Balancing energy conservation, reduced consumption, and profitability doesn't deter us from delivering peak performance.



Customer-Centric Assistance

Just as our machines care for the ice, we cherish our relationships with our customers: not only before the purchase but also during the delivery and afterwards. We meet our clients' unique requirements even during the production process, tailoring our approach to their needs.



LITHIUM
PETROL / GASOLINE

PINGUINO





Handy and easy to use: the new
ice resurfacer by WM technics is here
and ready to turn ice into perfect ice.

The handy ice resurfer for events and mobile rinks, ideal for ice surfaces up to 800 m² / 8,600 ft².

Whether it's a sports event or an ice skating rink, you can easily keep your designated ice surface flawlessly maintained with WM Pinguino.

This innovative, compact ice resurfer (measuring 3 meters in length and 2 meters in height) performs on par with larger professional machines: it efficiently planes the ice, ensuring perfect quality. Plus, its unique front seating position for the driver offers excellent visibility and a comfortably enjoyable driving experience.

Modern design, high quality, and easy maintenance – ice resurfacing for mobile rinks has never been this professional and comfortable!

	Snow tank volume	1 m ³ / compacted 1.25 m ³ 35.3 ft ³ / compacted 44.2 ft ³
	Water tank volume	340 l 90 gal
	Blade width	1,400 mm 55 1/8 in
	Fields of operations	Mobile / Event

“Agile, comfortable to use and outstanding ice resurfacing: With the WM Pinguino, we create the perfect ice conditions for our events!”

Raphael Fink
Pond Hockey Championship
Ritten / Italy





Safety and Protective Features

WM technics prioritizes safety and health above all. An exhaustive and independent evaluation conducted by [Suva](#), an accredited and recognized Swiss certification agency, confirms compliance with the provisions of the European Directive 2006/42/EC, which governs the protection against machinery accidents.

suva
CERTIFICATION

In compliance with Suva certification No. E 7164/2.e

Highlight

Front Seat

Ready, sit, go! On the WM Pinguino, the driver's seat is at the front, just like in a car, making operating the machine easier, **even for less experienced users.**

The front seating position ensures full vision, perfect peripheral vision, and ease of maneuvering, increasing safety for people, the machine, and the sports facility.



Full sight

Comfortable sitting position

Ease of maneuverability

Highlight

Blade replacement

Replacing the blade is **easy and quick**. There's no need to detach the planing unit. Just flip it upwards and remove the blade. Done!

You can quickly and safely replace the blade with just a few easy steps. You can change it effortlessly whenever needed, guaranteeing better ice quality throughout the season.



Quick & easy

Maximum safety

Constantly high ice quality

Highlight

Perfect ice maintenance

The WM Pinguino might be compact, but it planes just like a big professional machine, **ensuring top-notch ice resurfacing** even on mobile rinks. Plus, the optional brush attachment guarantees clean edges.



Planing unit



Mechanical blade setting



Brush



Open snow tank

340 liters of water

Enormous planing power

Easy emptying

Highlight

Lighting

Efficient lighting for the **best visibility**. The combination of LED lights and powerful headlights always ensures optimal visibility.



Front lighting



Side work light



Flashing warning light



Rear lighting

Energy efficiency

Perfectly integrated headlights

Excellent visibility

Highlight

Ease of transport

On to your next event? The **low-weight** WM Pinguino is fitted with lifting pockets for ease of transportation by forklift or trailer.



Retractable driver's seat (2 positions)



Ease of transport

Space saving

Reduced weight

Highlight

Easy handling

The Pinguino excels due to its **easy handling**. Its intuitive design and simple controls make it accessible to anyone, even those who have never driven anything similar.

Keep your ice surface in perfect condition and ensure safety for all activities. The Pinguino ensures optimal results.



Mobile ice rinks & frozen lakes

Training facilities

Occasional sports events

Highlight

Ease of maintenance

All machine parts are easily accessible without needing to dismantle any components, making maintenance quick, simple, and cost-effective while minimizing operational costs.



Tiltable seat



Good sight: Hydraulic oil level indicator



Easy maintenance service



Easily accessible engine compartment

Easily accessible engine compartment

Low maintenance costs

Faster maintenance service

TECHNOLOGY

Explore the WM Pinguino's standard features and numerous optional extras. We are also happy to customize the WM Pinguino to meet your needs.



Lithium

Facts & figures

Motor	Asynchronous motor
Drive power	10 kW
Battery Lithium	BlueLi 80V – 100Ah
Charger Power	3 kW
Battery charger connection	230V / 50Hz
Autonomy	ca. 1h 10 min.
Charging time	ca. 2h 40 min.
Weight when empty	1,250 kg (basic outfit)
Water tank	340 l
Snow tank	1 m ³ – compacted 1.25 m ³
Transmission	Continuously adjustable hydraulic four-wheel drive
Axles	Single wheel drive
Steering	Hydraulic
Footbrake	Hydraulic
Parking brake	Mechanical parking brake on rear wheels
Hydraulic system	18 cm ³ axial piston pump for drive, 6 cm ³ work units + cylinder movements, 4.4 cm ³ steering
Diameter of screw conveyors	vertically ø 175 mm horizontally ø 170 mm
Tires	5.00R12 83/81P 2 rows of spikes
Wheel rims	12" x 5" with hubcaps

Standard equipment

All-wheel drive
Parking brakes
2 board guide rollers
Watertank-snowbin made of stainless steel
Spring suspended drivers seat
Horn
Easily accessible engine compartment (tiltable driver's seat, hydraulically tiltable snowtank)
Hydraulic power steering
2 hydraulically powered screw conveyors
Hydraulic carriage pressure system
Hydraulic opening and closing of snow bin cover
Manual blade adjustment
Tiltable planing device for easy, safe blade changing
Tiltable operator's platform (2 positions)
1 blade
1 towel
Scope of delivery set



suva
CERTIFICATION



In conformity with Suva no. E 7164/2.e
type-examination certificates

Petrol / Gasoline

Facts & figures

Engine	Honda GX690RH, 2 cylinder 688 cm ³
Power	16.5 kW / 22.1 HP PS - 3,600 rpm
Weight when empty	1,100 kg (basic outfit)
Water tank	340 l
Snow tank	1 m ³ – compacted 1.25 m ³
Fuel tank	15 l
Transmission	Continuously adjustable hydraulic four-wheel drive
Axles	Single wheel drive
Steering	Hydraulic
Footbrake	Hydraulic
Parking brake	Mechanical parking brake on rear wheels
Hydraulic system	18 cm ³ axial piston pump for drive, 6 cm ³ work units + cylinder movements, 4.4 cm ³ steering
Diameter of screw conveyors	vertically ø 175 mm horizontally ø 170 mm
Tires	5.00R12 83/81P 2 rows of spikes
Wheel rims	12" x 5" with hubcaps

Standard equipment

All-wheel drive
Parking brakes
2 board guide rollers
Watertank-snowbin made of stainless steel
Spring suspended drivers seat
Horn
Easily accessible engine compartment (tiltable driver's seat, hydraulically tiltable snowtank)
Hydraulic power steering
2 hydraulically powered screw conveyors
Hydraulic carriage pressure system
Hydraulic opening and closing of snow bin cover
Manual blade adjustment
Tiltable planing device for easy, safe blade changing
Tiltable operator's platform (2 positions)
1 blade
1 towel
Scope of delivery set

suva
CERTIFICATION



In conformity with Suva no. E 7164/2.e
type-examination certificates



Included in delivery (Lithium & Petrol / Gasoline)



1 blade in
transport sheath



Felt spreader towel



2 rubber mats



6 mm hex socket T wrench



Cross-key with nut



Laceration-proof
safety gloves



Grindstone



Water connector



Fuse set



Set ABS
fastening material



Operating instructions



Online spare
parts catalogue

Dimensions

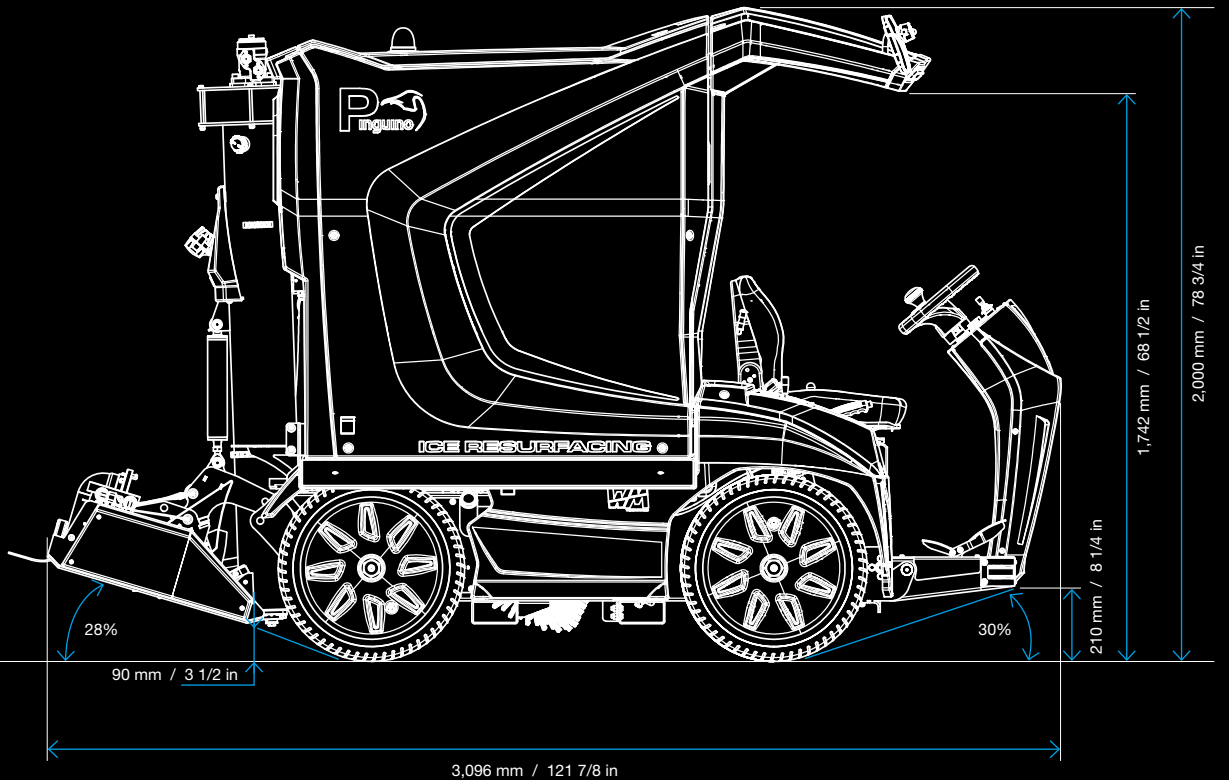
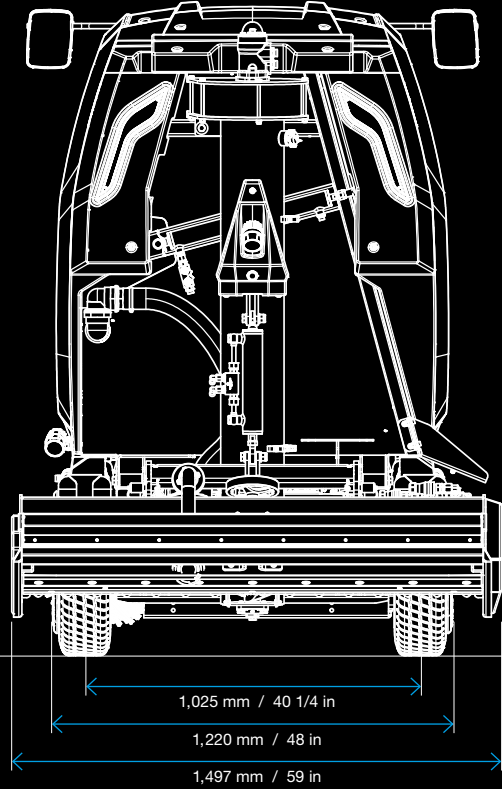
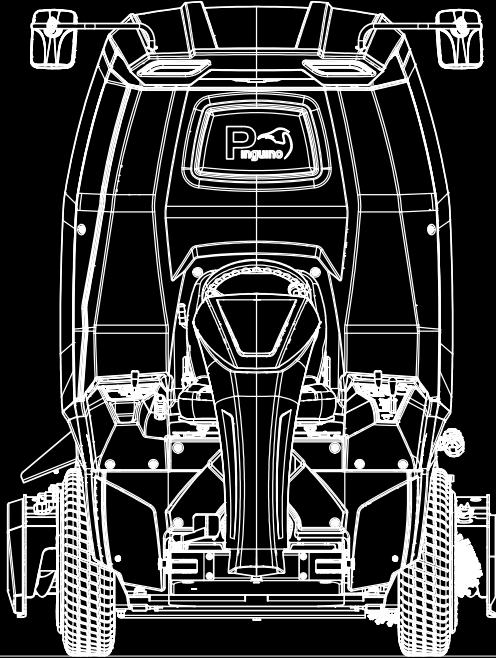

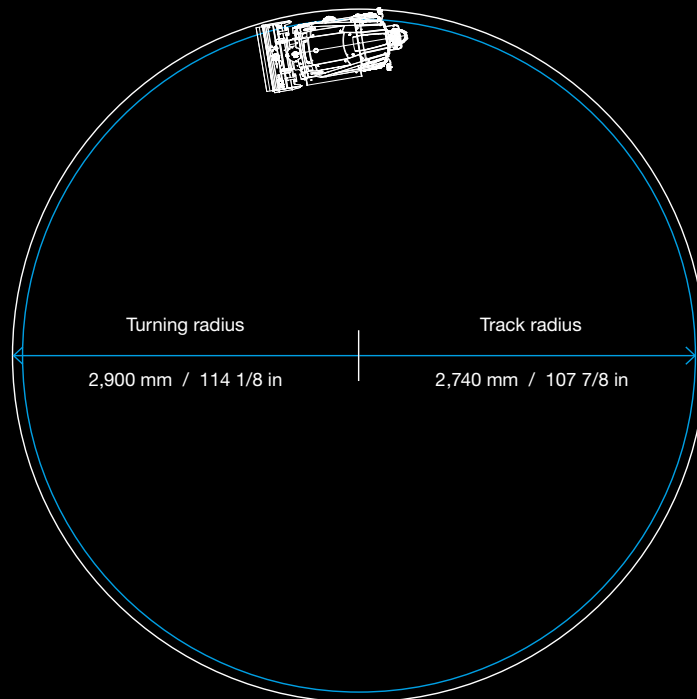
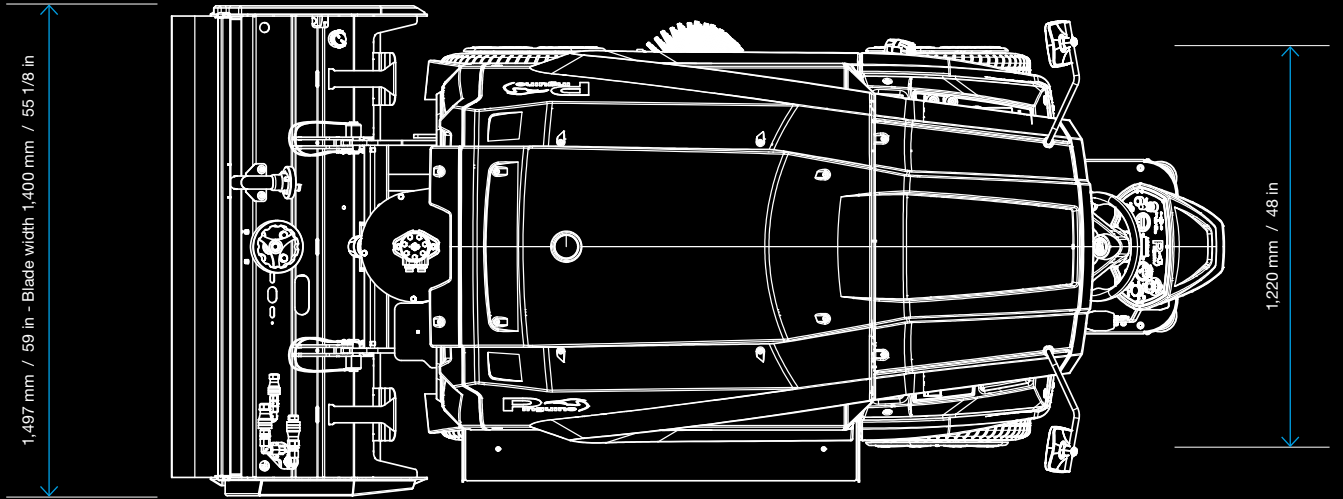

Options



Wash systems



Screw conveyor
wash system
vertical



Screw conveyor
wash system
horizontal

Dasher board processing



Brush

Overview & Security



Side mirrors front
left & right



Rear-view camera



Protective guard for
board guide rollers

Comfort



Hydraulic blade adjustment



Slide extension



Water tank signage



Conveyor screw overload warning system



Acquastop valve with time relay

Lighting



Front and working lights



Flashing warning light

Personalization



Custom wrap 4c
digital print

Service



Spare wheel 12"



Diagnostic cable
Controller



Diagnostic cable
BMS

Replacement parts



Blade



Felt spreader
towel



Terry spreader
towel

STRENGTHS

WM technics, your guarantee for the highest standards. With our ice resurfacers, we guarantee excellent design, in-house production, easy maintenance, and quick access to spare parts.

At WM technics, we strive for excellence at every stage of our work. Our machines are the result of high-quality components and meticulous design that minimizes maintenance effort. Designed, manufactured, and assembled in our own facilities, we guarantee top quality and timely deliveries. From component to the finished product - every step is closely monitored to deliver to you **the ice resurfacing machines of the future.**

User friendliness



Through the use of top-quality components together with a well-planned design, maintenance work is extremely simple and is reduced to a minimum.

Quality guarantee



Our products are developed, manufactured, and assembled in-house at our facilities. This is the only way we can guarantee the best quality and punctual delivery times.

The right replacement part, every time



Order your spare parts easily and conveniently from our online portal: Our series number and digital image system enable you to find the part you need with just one click.

Series production



All WM technics vehicles are series-manufactured. We know exactly which parts have been used in each series run, and can deliver the correct spare parts to you at all times. At the same time, a number of optionals can be retrofitted with minimum effort and maximum precision, even years later.

Service and support



Our well-networked, international team of technicians undergo constant training and will be delighted to help you whenever you require assistance.

Quality consciousness



From the manufacture of individual parts right through to the final quality-control inspection: Every step of the process is carried out and monitored with the utmost precision. Each and every member of our staff is well-trained in his specialist field, and carries out all tasks conscientiously. This is a great advantage for our customers, who can be sure of receiving a technologically sophisticated product which has been manufactured to the very highest quality standards.

PRODUCTS

Explore the world of WM technics:
State-of-the-art Design meets quality.
Start your journey with our innovative
ice resurfacers to #perfectIce

Compact





The name “Compact” says it all - and it’s the prime choice for larger mobile ice rinks. Thanks to its optimal dimensions and the volume of its water and snow tanks, it’s not just efficient but also intuitive and user-friendly. Whether you’re old hands in the ice game or just getting started, its easy operation and superior driving comfort will win you over.

The cherry on top? The Compact delivers ice quality that’ll captivate not just you but your clients, too. For ice masters, what’s better than delighted guests enjoying flawless ice? With the Compact, you’ve got the perfect ally for dazzling ice rink experiences.



Compact

The **Compact** is your ideal ally for outstanding results on the ice rink.

 Snow tank volume	1.8 m ³ / compacted 2.25 m ³ 63.6 ft ³ / compacted 79.5 ft ³
 Water tank volume	600 l 158 gal
 Blade width	1,700 mm 66 7/8 in
 Fields of operation	Mobile / Event

Shira





Prepare to be dazzled by the Shira! Not only does she operate electrically and whisper-quiet, but she also impresses with her incredibly user-friendly controls. Ice maintenance becomes a breeze with keyboard commands, a clear info display, and an automatic mode. Need to get hands-on? No worries! Quick access to the mechanics means

maintenance and service are done in a flash, saving you a pretty penny.

The icing on the cake: The ice quality is simply top-notch, right down to the last detail. And, even with its traditional blade exchange system, she boasts unbeatable value for money. Discover the Shira – your new star on ice!



Introducing **Shira**, your new shining ice star.

	Snow tank volume	3 m ³ / compacted 3.6 m ³ 106 ft ³ / compacted 130.7 ft ³
	Water tank volume	1,000 l / 1,350 l / 1,750 l 264 gal / 356 gal / 475 gal
	Blade width	2,100 mm / 2,300 mm 82 5/8 in / 90 1/2 in
	Fields of operation	Pro / Heavy duty

Mammoth

Mammoth is the powerful ice resurfacer designed for stadiums and ice surfaces up to 1,800 m².

Powerful, maintenance-free AC motors, large snow and water tanks, and a quick blade change system designed for whatever challenge may come. Thanks to its compact design, the

machine achieves a minimal turning radius, allowing for fast, efficient, and non-deviating ice surface treatment.

Maximum stability? You bet! The sprung edger is mounted directly on the WM Mammoth, ensuring maximum stability and the best working performance.



High-performing, accurate, and automated: **Mammoth**. Unprecedented resurfacing for unprecedented ice quality.

❄️	Snow tank volume	3 m ³ / compacted 3.6 m ³ 106 ft ³ / compacted 130.7 ft ³
💧	Water tank volume	1,000 l / 1,350 l / 1,750 l + 264 gal / 356 gal / 475 gal Snow tank-water tank connection 2,000 l / 2,350 l / 2,750 l 528 gal / 620 gal / 739 gal
📏	Blade width	2,100 mm / 2,300 mm / 2,500 mm Blade change < 60 seconds 82 5/8 in / 90 1/2 in / 98 1/2 in
🏠	Fields of operation	Pro / Heavy duty





evo²

Whether it's vast ice rinks or grand stadium ice surfaces – with our evo², you'll glide effortlessly over any expanse. The swift blade changes, ultra-light blades, and the harmony between the board mill and brush ensure perfect ice. Every ride feels like a leisurely spin inside the spacious cabin (included as standard!). And when the

going gets tough? Just lift the cabin and experience a swift, cost-effective service. With the powerhouse evo², ice maintenance becomes a piece of cake!



Harnessing the strength of evo² makes ice maintenance effortless!

	Snow tank volume	4.1 m ³ / compacted 5.1 m ³ 145 ft ³ / compacted 180 ft ³
	Water tank volume	1,200 l / 1,400 l / 2,000 l 317 gal / 370 gal / 528 gal
	Blade width	2,300 mm / 2,500 mm Blade change < 60 seconds 90 1/2 in / 98 1/2 in
	Fields of operation	Pro / Heavy duty

WM technics GmbH

Breiner Straße 15
I-39053 Blumau
T. +39 0471 353 332
info@wm-technics.com
wm-technics.com

Follow us on

YouTube: *WM ice*
Facebook: *WM ice*
Instagram: *WM ice*
LinkedIn: *WM technics*

